

M.T.Ceballos<sup>1</sup>, B. Cobo<sup>1</sup>, P.Peille<sup>2</sup>, J.Wilms<sup>3</sup>, T.Brand<sup>3</sup>, T.Dauser<sup>3</sup>, S.Bandler<sup>4</sup>, S.Smith<sup>4</sup>  
<sup>1</sup>IFCA, Spain; <sup>2</sup>IRAP, France; <sup>3</sup>Remeis Observatory & ECAP, Germany; <sup>4</sup>GSFC, USA

SIRENA is the software aimed at performing the on board event energy reconstruction for the *Athena* calorimeter X-IFU. This on board processing will be done in the X-IFU Digital Readout Electronics (DRE) unit and it will consist in an initial triggering of event pulses followed by an analysis (with the SIRENA package) to determine the energy content of such events.

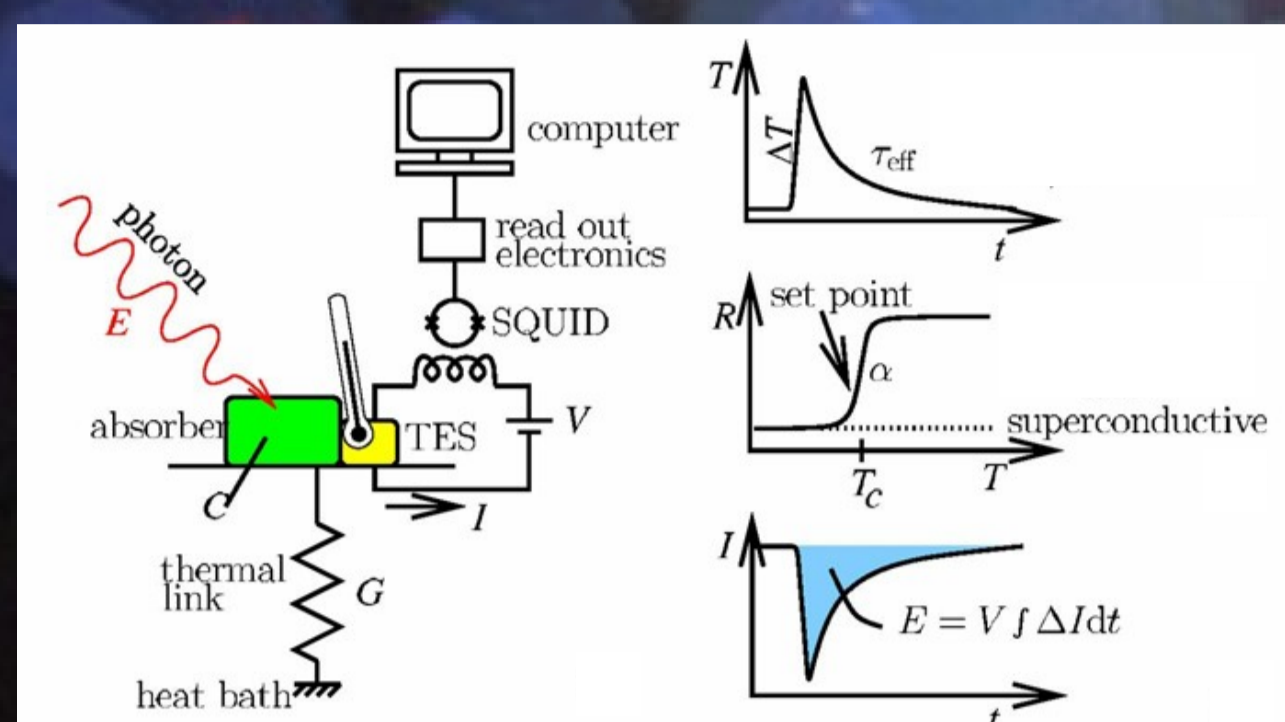

Response of X-IFU microcalorimeter to X-ray incoming photons are electrical pulses.

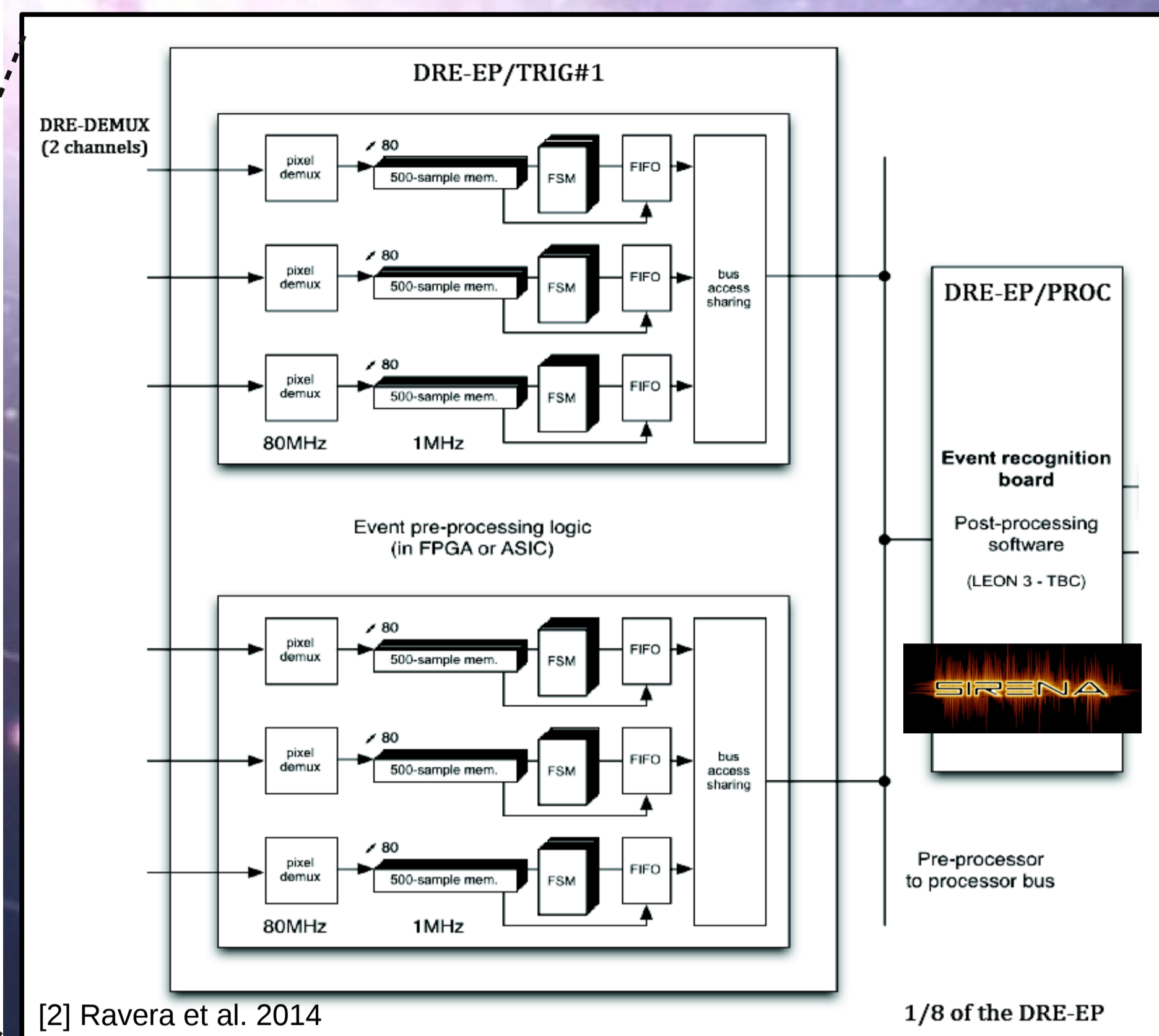
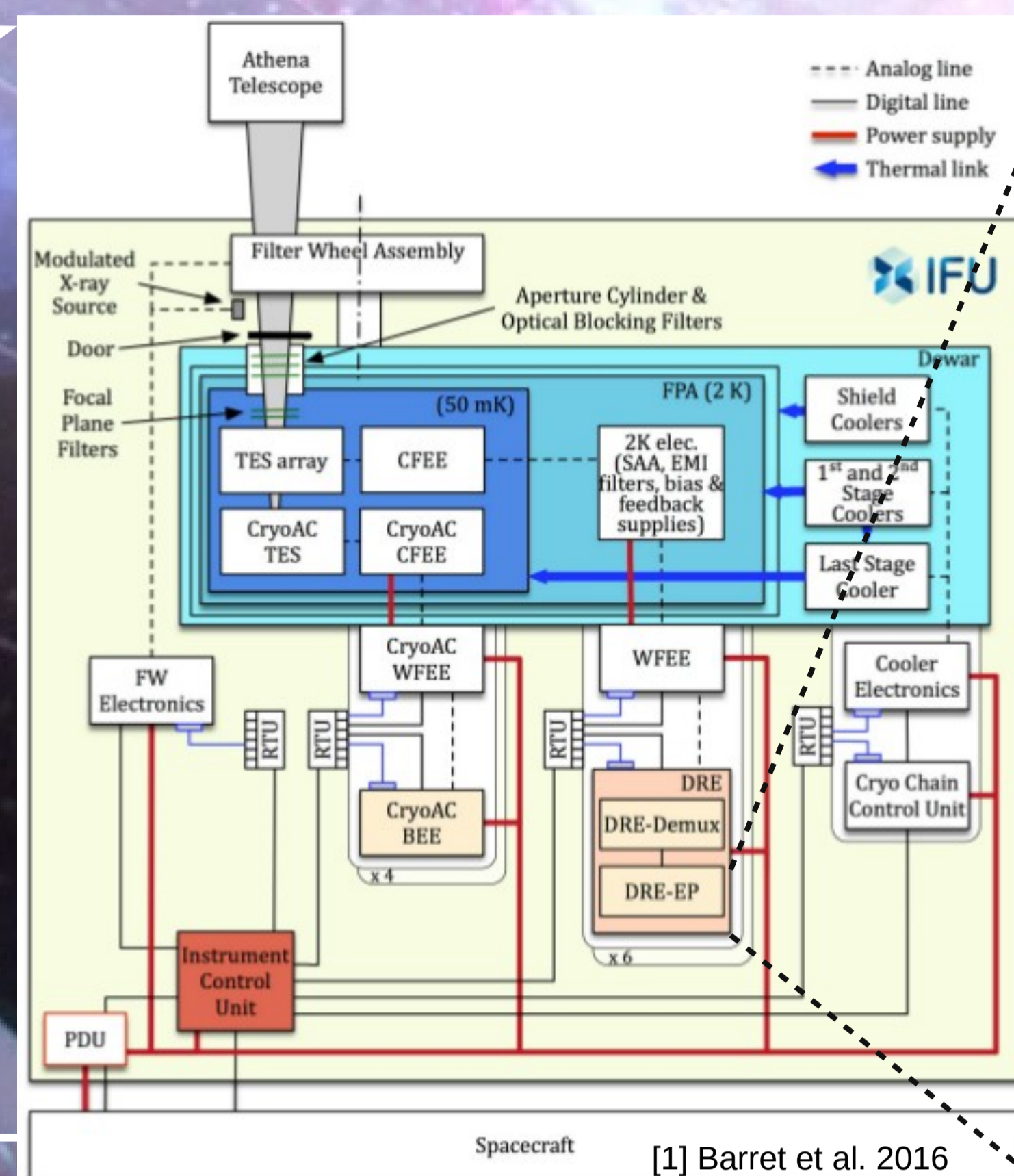

Pulses must be detected (triggered) and then its energy must be reconstructed on board by the Event Processor in the Digital Readout Electronics Unit by the SIRENA software

## Development under SIXTE environment for end-to-end simulations

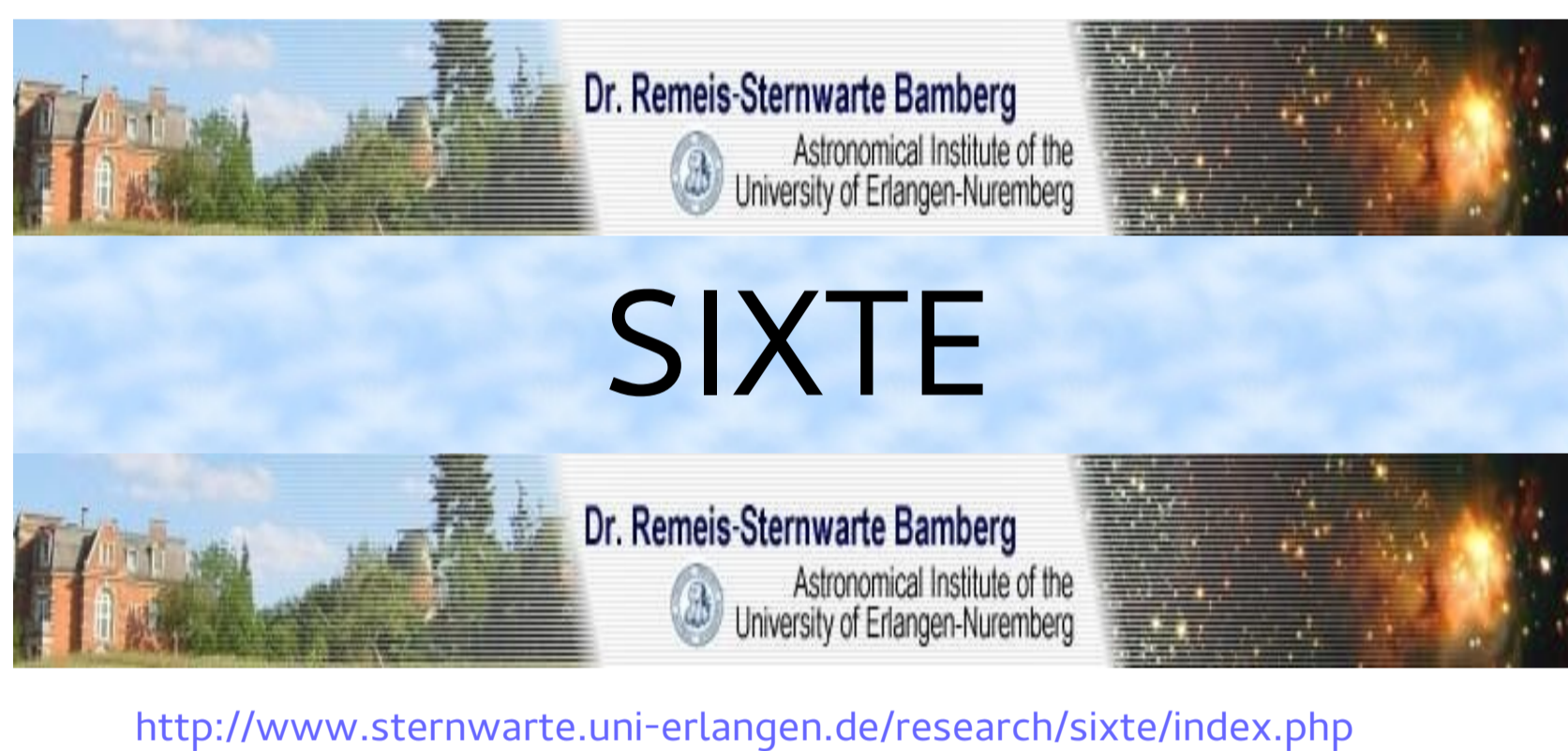

Simulation of X-IFU TES physics (tool: **tessim**)

Numerical solution of differential equations for  $T(t)$ ,  $I(t)$ <sup>[3]</sup>

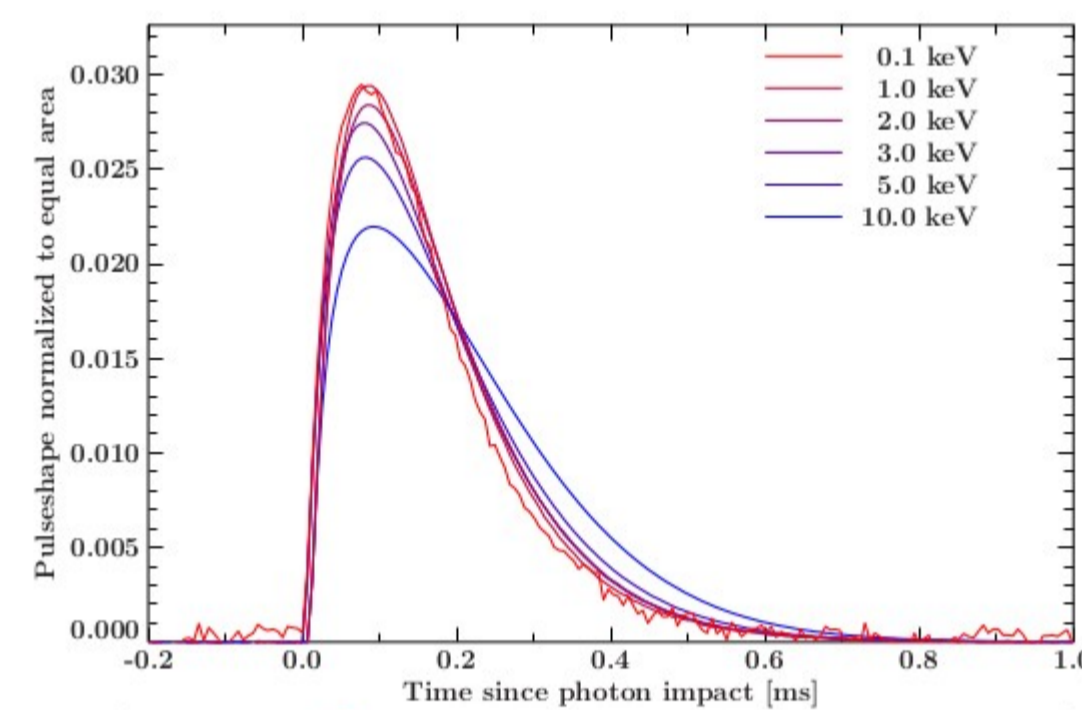

## RECONSTRUCTION METHODS

<http://venus.ifca.unican.es/SIRENA/>



- ✗ Pulses are scaled versions of a single shape: Response of detector is linear
- ✗ Noise is stationary

Data  $D(t) = H \times S(t)$   
 Minimize  $\chi^2 = \sum \frac{[D(f) - H \times S(f)]^2}{NOISE^2(f)}$   
 $E \sim \sum D(t) OptFil(t)$

- \* Least squares optimal filter varying with photon energy. Accounts for noise non-stationarity & detector non-linearity
- \* Calibration with densely spaced narrow lines
- Model template (M) + covariance matrix (deviations from model) + weight matrix ( $W=C^{-1}$ )
- Minimize  $\chi^2 = (Data - M) W (Data - M)$
- Energy =  $f(E_\alpha, E_\beta, U, M_\alpha, M_\beta, W_\alpha, W_\beta)$
- $\alpha, \beta$ : calibration points that straddle the unknown signal U

Optimal Filter after transforming signal  $I_{TES}$  to  $R_{TES}$ :  
 ✓ Removes non-linearity due to the bias circuit

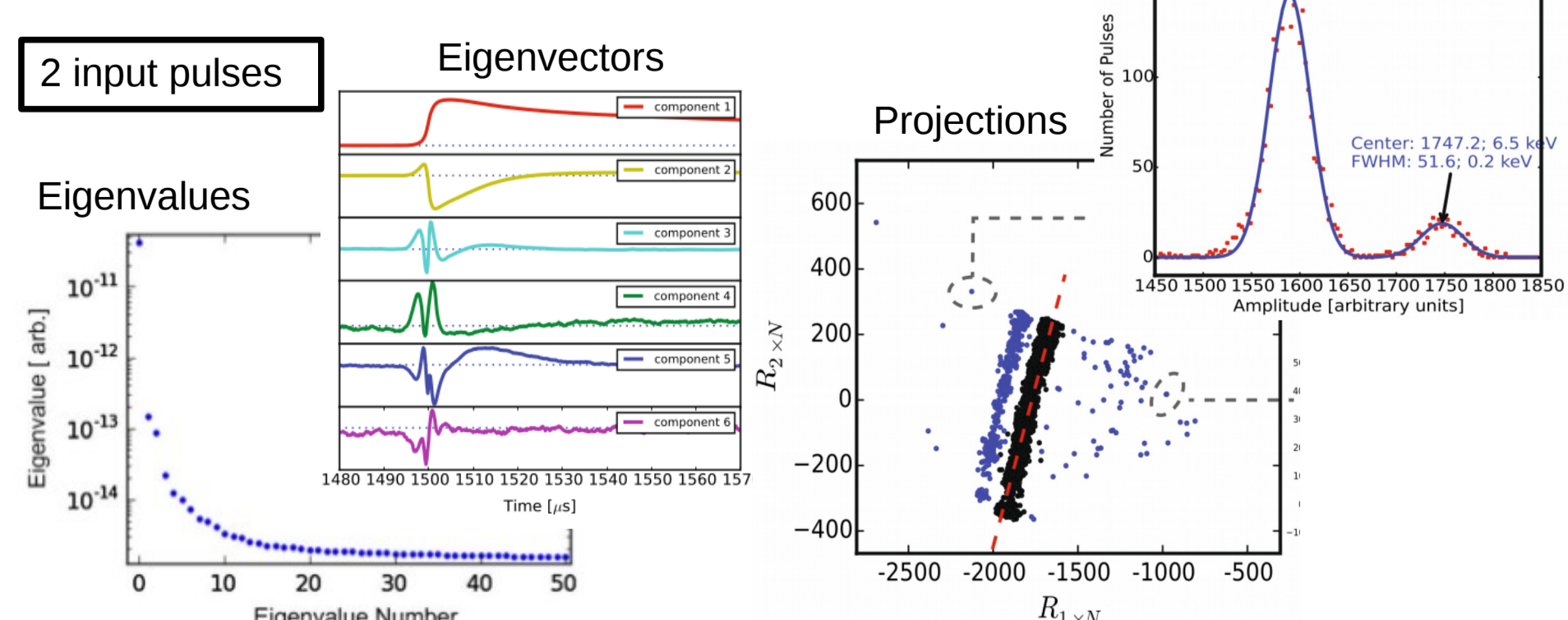
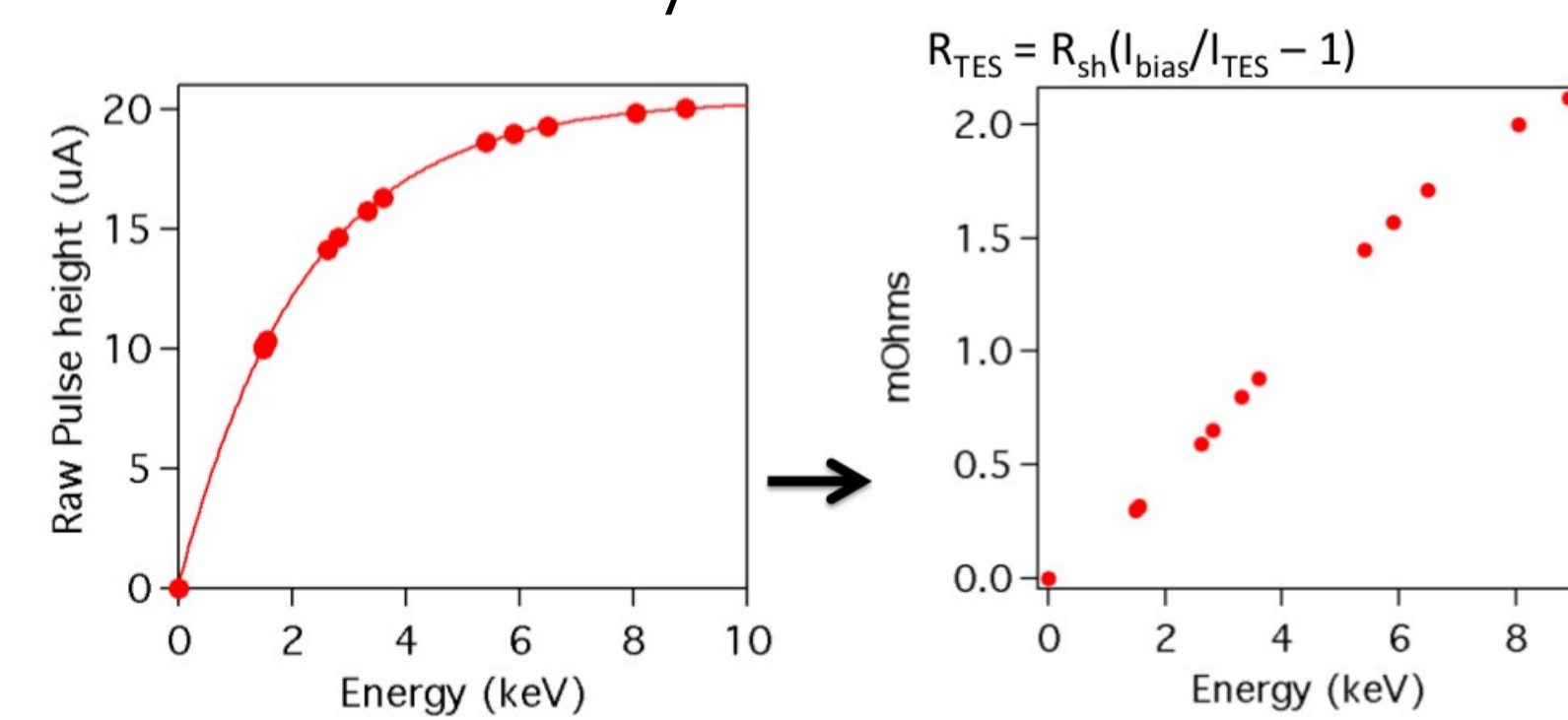

- ### COMPARATIVE
- \* resolution performance (similar)
  - \* computational cost (larger for covariance)
  - \* calibration needs (larger for covariance)
  - \* automation (more difficult for PCA)
  - \* robustness at high count rates
  - \* response to detector nonlinearity (resistance)

